

---

**SYNETECH**

**Piscis Infinity A1 SKU A17582**

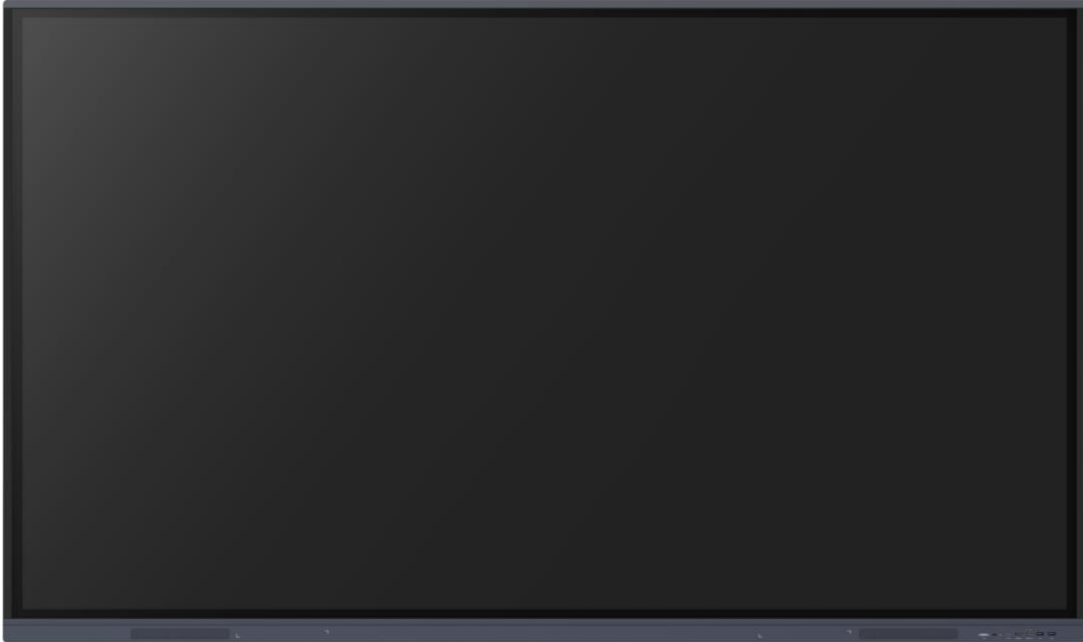

**Service Manual V1.0**

Document Revision History					
Version	Modification Date	Page NO.	Updated Instructions	Reviser	Confirmed by
1.0	2024/05/08	All	Release Version	Sunny	Spencer
1.1	2024/05/15	All	Release Version	TianLV Sheng	Spencer

---

## CONTENT

Safety Instructions .....	4
I. Safety warning.....	4
II. Notice .....	5
Product Basic Specifications.....	6
I. Product Appearance.....	6
II. Electrical Diagram .....	8
Disassembly guide .....	9
I. Exploded Views .....	9
II. Screw fastening torque reference table.....	10
III. Shell Disassemble.....	13
IV. Circuit Boards Disassemble .....	14
V. Touch Frame Disassembly .....	17
Internal Cables.....	21
I. Cable Connection Guide.....	21
II. Cable Connection Diagram.....	21
Key Parts List (For reference only) .....	23
Principle of Key Components .....	24
I. Main board .....	24
II. SI07 WiFi Connector board .....	32
III. Touch Frame .....	32
Troubleshoot steps .....	34
I. LED does not turn red .....	34
II. LED does not turn blue.....	35
III. Touch issue .....	36
IV. PC issue.....	37
V. LED turn blue but no backlight.....	38
Firmware update procedure .....	39
I. Upgrade All.....	39
II. Touch frame Update.....	40

---

# Safety Instructions

Please read the safety information carefully before installing, maintaining, or disassembling this product.

## I. Safety warning

The current of power supply, telephone and communication cable is dangerous and the on/off button, power switch on the device do not cut off the current completely. To avoid the danger of electric shock:

- Be aware that the device may have several power supply cables at the same time. To cut off the power, make sure all power supply cables are disconnected.
- Do not connect or disconnect any cables, install, maintain, or reset the product during thunderstorm.
- Connect all power cables to the right and use the well grounding power supply socket.
- Connect all devices to the proper connector.
- Connect or disconnect cables with one hand is recommended.
- Do not turn on any device when there is a fire, flood, or collapse of a house.
- Please disconnect the power cable, remote communication system, network, modem, and other devices before opening the screen, unless otherwise specified in the installation and configuration process.
- When the product is installed, moved or opened, the step of cable connection or disconnection is provided as below.

<p>To connect cables :</p> <ol style="list-style-type: none"><li>1. Turn off all devices.</li><li>2. Connect power cords to devices.</li><li>3. Connect signal/ communication cables to devices.</li><li>4. Connect the power cord to power supply socket.</li><li>5. Turn on devices.</li></ol>	<p>To disconnect cables :</p> <ol style="list-style-type: none"><li>1. Turn off all devices.</li><li>2. Unplug power cords from the socket.</li><li>3. Disconnect signal /communication cables from connector.</li><li>4. Disconnect the power cords from devices</li></ol>
--	---

---

## II. Notice

1. The AC switch or button mightn't cut off the AC power supply, Please disconnect the AC cable if you need.
2. Do not remove any cover of the module with the danger label attached.

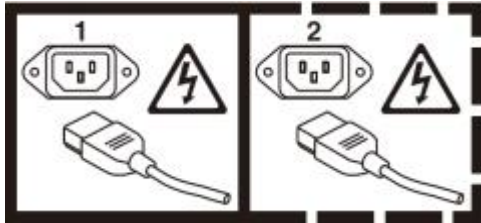

---

## Product Basic Specifications

### I. Product Appearance

➤ Front view

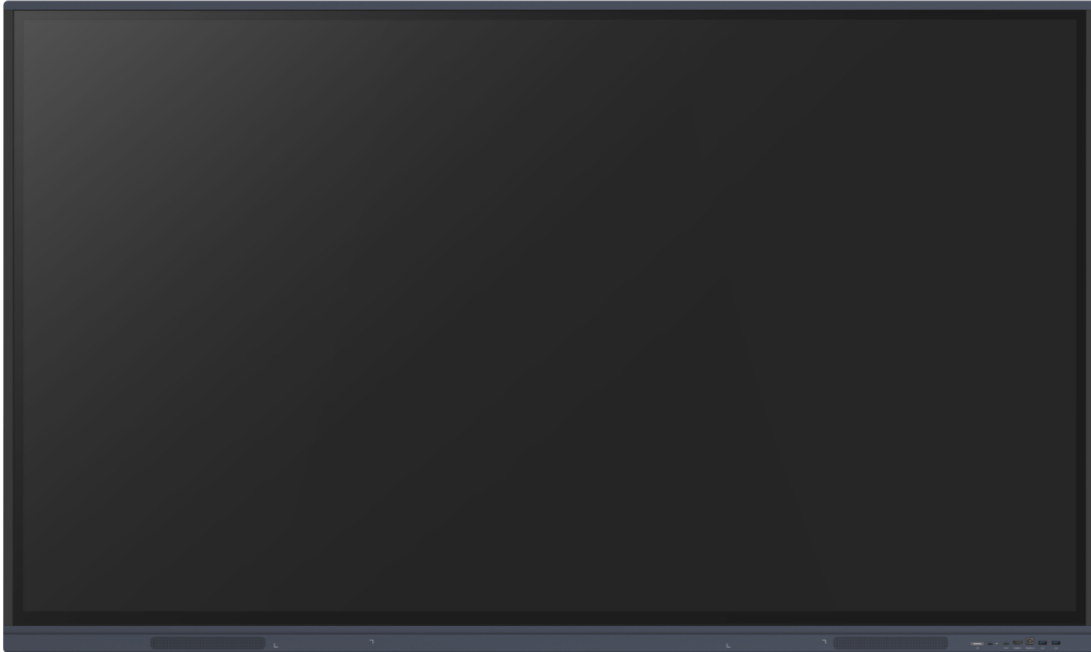

➤ Back view



---

➤ Side view

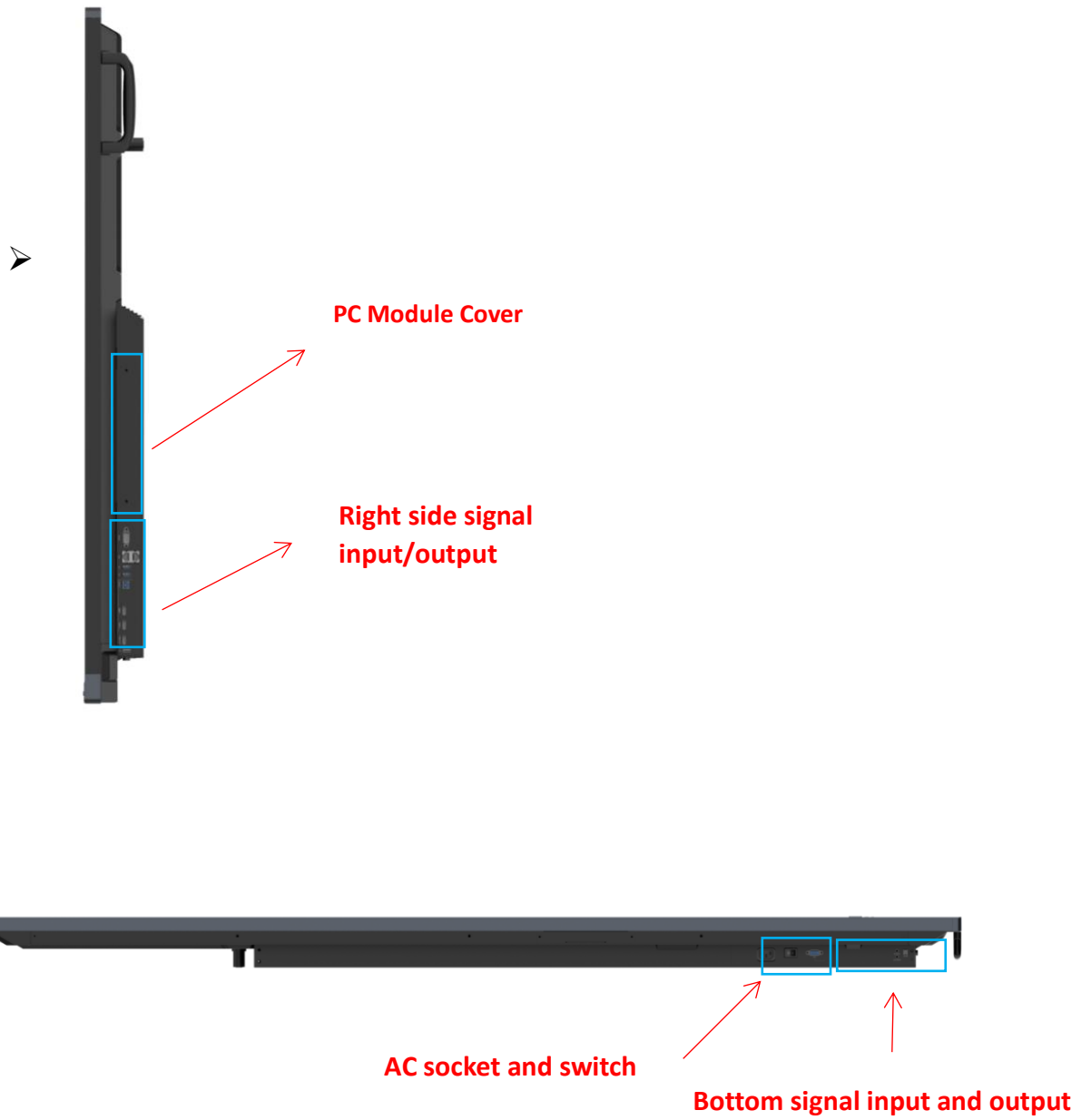

➤ Back view of the screen

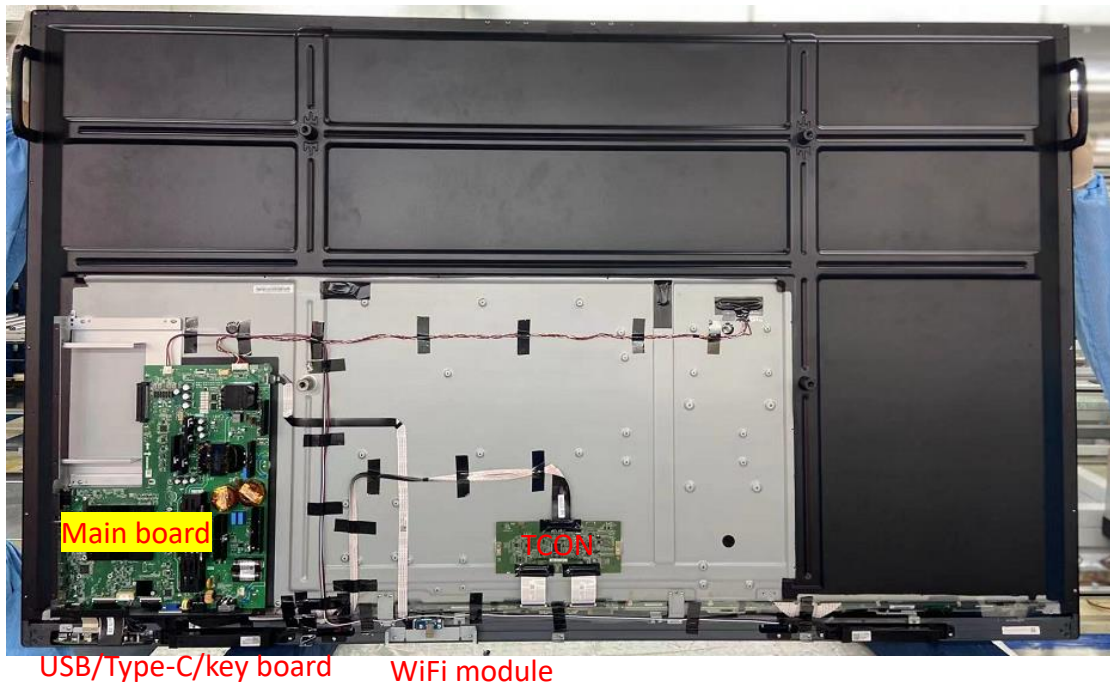

## II. Electrical Diagram

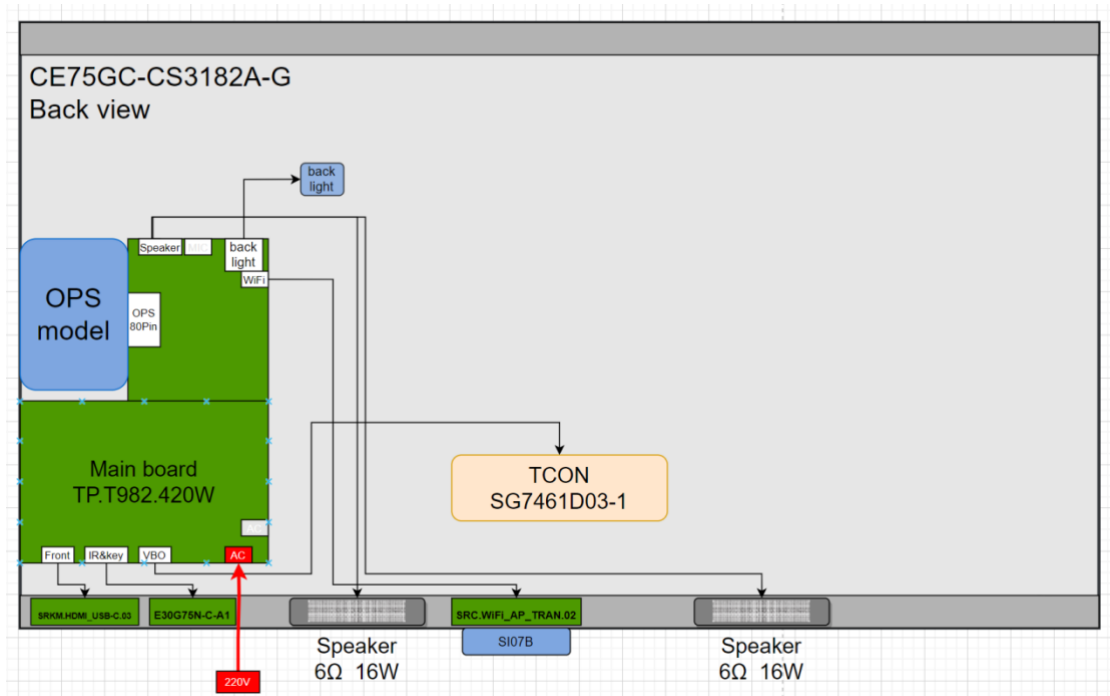







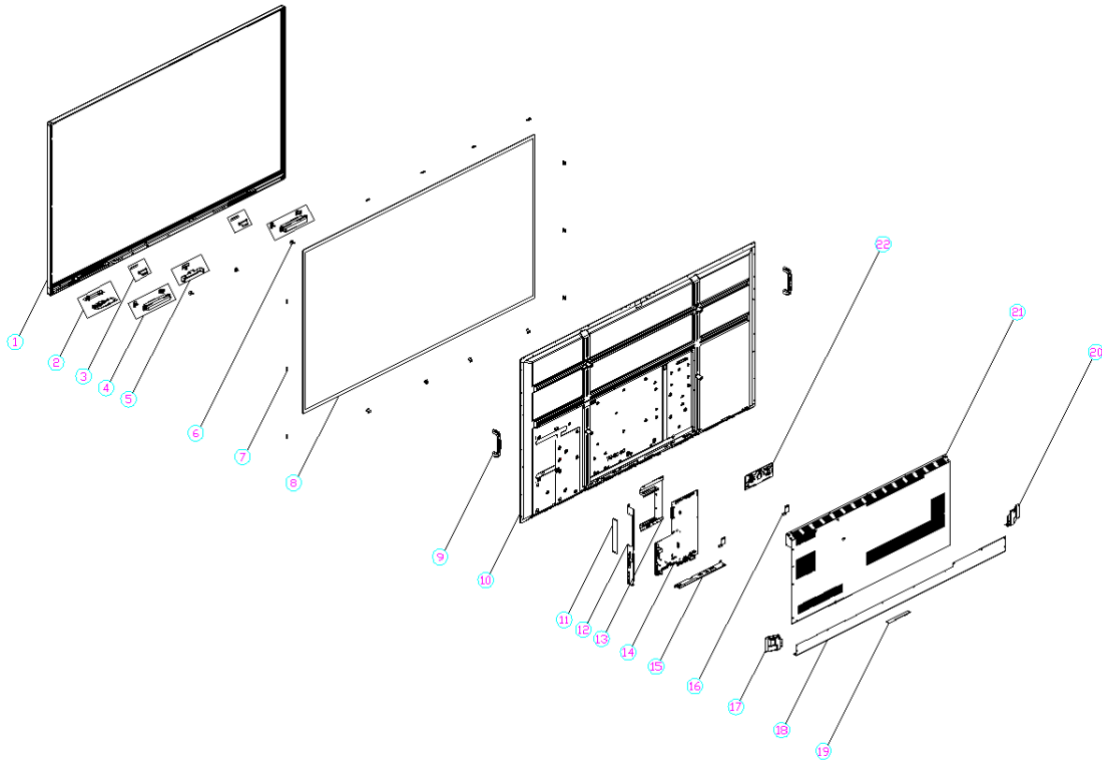

# Disassembly guide











## I. Exploded Views











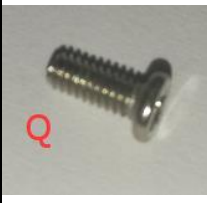

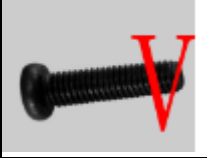

NO.	NAME	QTY	NO.	NAME	QTY	NO.	NAME	QTY
1	Front Frame	1	10	Backlight module	1	19	WiFi Cover	1
2	Key board	1	11	OPS Cover	1	20	Right small back cover	1
3	Magnet	2	12	Side terminal bracket	1	21	Big back cover	1
4	Speaker	2	13	OPS Bracket	1	22	T-CON board	1
5	WiFi module	1	14	Main board	1			
6	Small back cover bracket	3	15	Bottom terminal bracket	1			
7	Glass pressing block	10	16	Panel pressing block	2			
8	AG glass	1	17	Left small back cover	1			
9	Handle	2	18	Middle small back cover	1			

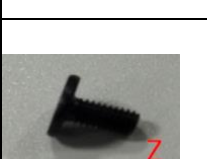
## II. Screw fastening torque reference table

Torque Requirement (except the hand screws and nuts)			
Screw Specification (mm)	Tightening Torque		
	N.M	(kgf.cm)	
M3x4~M3x8	0.5-0.7	5-7	
M4x8~M4x12	0.7-1.0	7-10	
M5	1.2-1.5	12-15	
Tool to Use			
ITEM	Screw Image	NAME	Specification
A		Phillips Countersunk Head Screw	KM3×8mm-Black Nickel plated
B		Phillips Countersunk Head Screw	KM3×3.8mm(φ4.6)-Black Nickel plated
C		Phillips Countersunk Head Screw	KM3×5mm-Black Nickel plated
D		Phillips Truss Head Screw	TM3×6mm-Nickel plated
E		Phillips Truss Head Screw	TM3×6mm-Black Nickel plated

F		Phillips Truss Head Screw	TM3×4mm-Silver Nickel plated
G		Phillips Truss Head Screw	TM3×4mm-Black Nickel plated
H		Phillips Truss Head Screw	TM4×8mm-Black Nickel plated
I		Phillips Pan Head Screw	PM4×8mm-with external tooth washer - Nickel plated
J		Phillips Pan Head Screw	PM5×16mm-with external tooth washer -Black Nickel Plated
K		Phillips Pan Head Screw	PM5×6mm-Black oxidized
L		Phillips Pan Head Screw with Washer	PWM4.0×6mm-Nickel Plated
M		Phillips Flat Head Screw	CM3×6mm-Nickel Plated
N		Phillips Flat Head Screw	CM4×20mm-Black Nickel Plated
O		Phillips Countersunk Head Tapping Screw	KA3×10mm-Black Nickel Plated

P		Phillips Truss Head Tapping Screw	TB4×10mm-Black Nickel plated
Q		Phillips C Head Screw	CM2×5mm-Nickel plated
R		Phillips Flat Head Screw (Non-standard)	CM3×4mm-Nickel Plated (Non-standard)
S		Hand screw (Non-standard)	M3×11mm(L=28)-Black Nickel Plated
T		Hand screw (Non-standard)	M3×7.5mm(L=21.5)-Black Nickel Plated
U		Nut	M3×5.3mm-Nickel Plated
V		Phillips Pan Head Screw	PM5×20mm-Black Nickel plated
W		Phillips Truss Head Screw	TM3×8mm-Black Nickel plated
X		Phillips Flat Head Screw	CM3×10mm-Black Nickel plated
Z		Phillips Flat Head Screw	CM3×6mm-Black Nickel plated

A1		Hand screw (Non-standard)	Customize-M3×4×7-14.5mm-Black Nickel plated
A2		Phillips C Head Screw	CM4×6mm-Black Nickel plated
A3		Phillips Truss Head Screw	TM3×5mm-Black Nickel plated
A4		Screw	PM4.0×14.0mm-Black Nickel plated
A5		Cross recessed C-head screws	CM3×5mm--Silver

### III. Shell Disassemble

#### 1. Screw Location

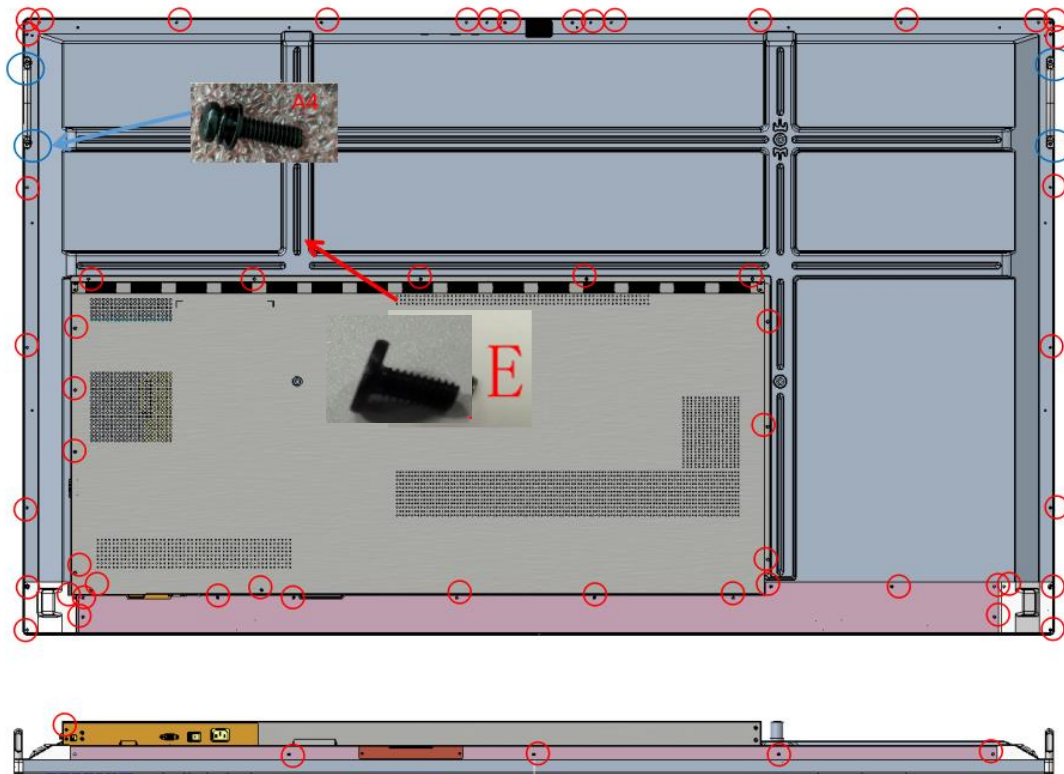

STEP 0: Get machine from the movable bracket and lie it down on the table( Be careful on protection)

STEP 1: Disassemble the bottom of the small back cover and the small back bracket, the handle, all the screws on the back frame, the screws for the small back cover, the screws for the big back cover.

STEP 2: Remove all back covers by hand.

STEP 3: Completed.

Tips: Please refer to "IV. Circuit Boards Disassembly" for the disassembly and repair of the board.

## IV. Circuit Boards Disassemble

⚠ Before removing the entire rear case, it is recommended that the machine screen face down flat on the platform, and then unscrew the wall-mounted bar with a screwdriver. The above diagram shows the location of the screws of the entire rear case, different colors represent different types of screws, after unscrewing these screws, you can remove the entire rear case.

---

**⚠** Please note that the tightening torque used must be in accordance with the reference values for the particular type of screw. otherwise the screws may be permanently damaged.

1. Screw Location

◆ Main Board

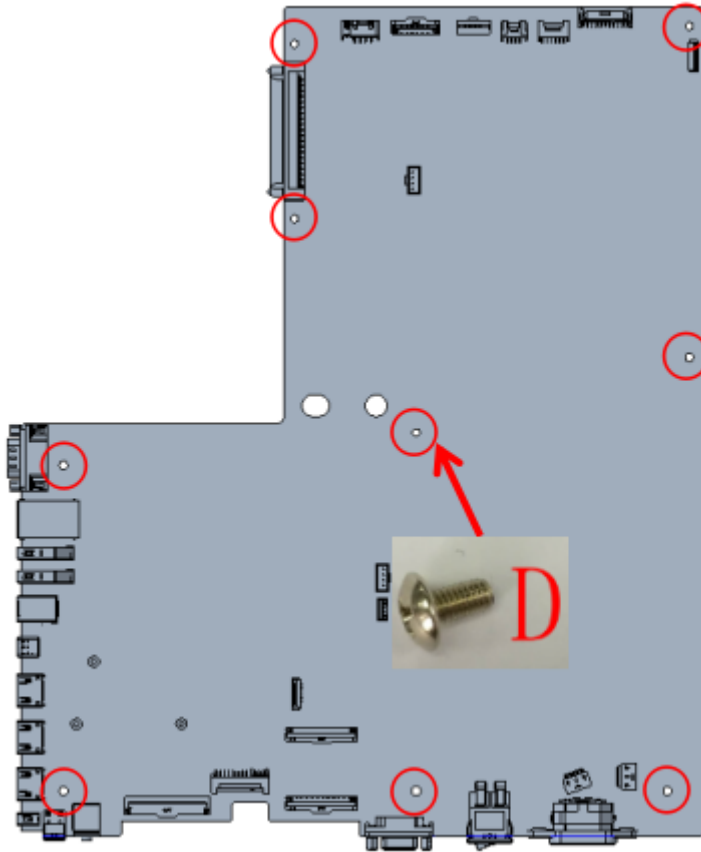

◆ TCON

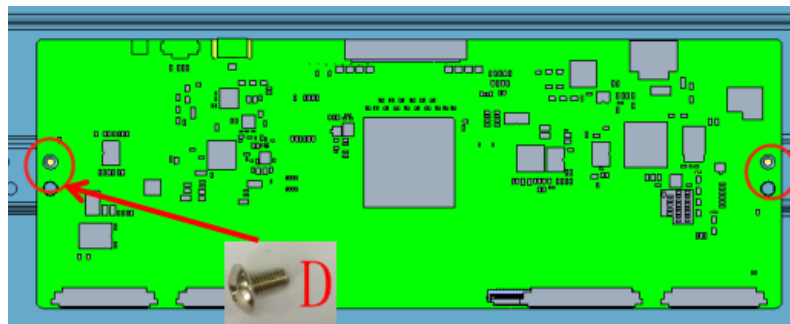

◆ USB Board

(1) Take off the screws of USB board bracket

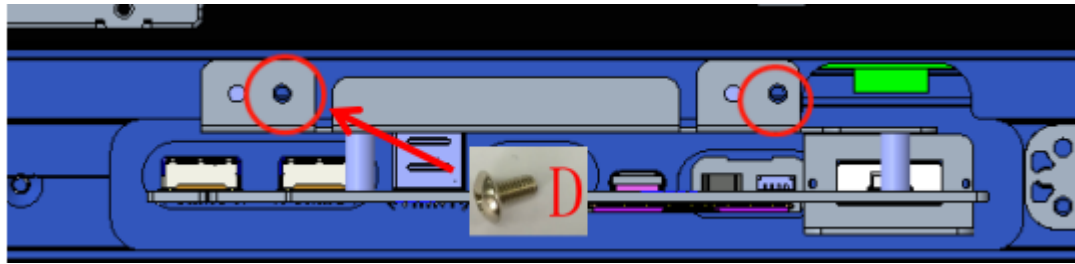

(2) Remove the screws and take USB board

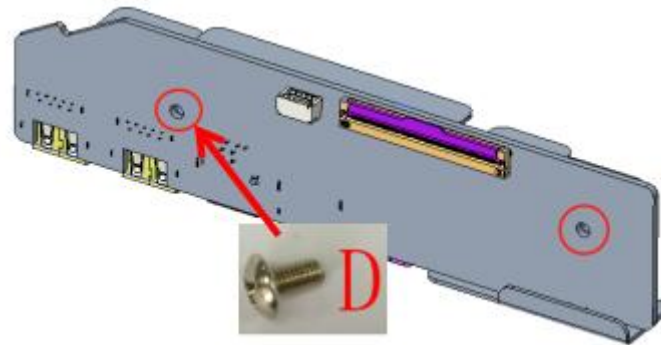

◆ WiFi board

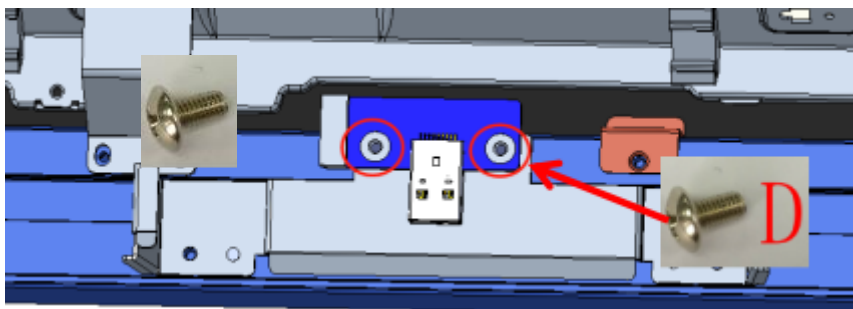

## 2. Maintenance Description

- To replace the circuit boards you need to remove first the rear covers and wires.
- To replace the **main board**, you need to remove the lower terminal block, the side terminal block.
- Cut off the power before performing replacement, so as to prevent any short circuit resulting from contact of wires.

**⚠ Please note whether the ports of the cables are properly connected in order to prevent the component from being burnt due to inserting in the wrong ports.**



---

## V. Touch Frame Disassembly

STEP 0: Get machine from the movable bracket and lie it down on the table( Be careful on protection)

STEP 1: Disassemble the bottom of the small back cover and the small back bracket, the handle, all the screws on the back frame, the screws for the small back cover, the screws for the big back cover.

**⚠** Recommend you keep some screws on corner to prevent the OC dropping during panel flipping process.

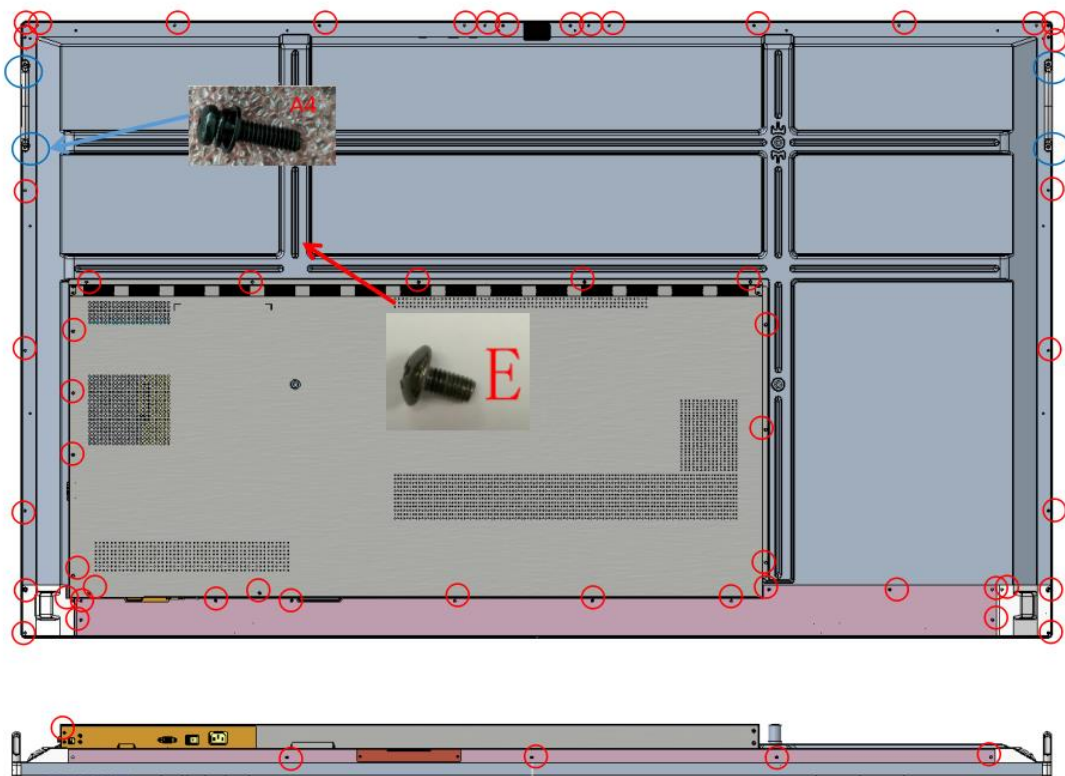

STEP 2: Remove the screen pressing block that fixes the OC and the bezel, the bottom terminal bracket, the WIFI bracket and remove the wire between the bezel and the OC, the tape and source mylar, etc.



**Caution: Please pay attention to the FFC cables that connect to OC panel, Those cables are non-removable and cannot be repaired.**

STEP 3: disconnect the touch frame from the motherboard connection cable: use tweezers to press the snap of the touch cable connection block, while pulling out the cable by hand.

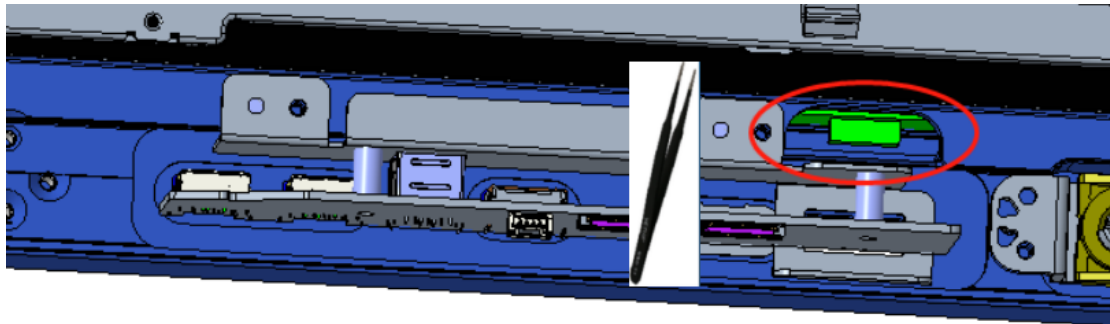

**Caution: This series of IFP without iron front frame, the flipping process should be careful to prevent the OC from falling!**

STEP 4: Turn over the machine 180° and put it on table, make sure the OC side face up.

STEP 5: Remove rest screws from back frame to bezel.

STEP 6: Lift up the front frame, then put it flat on table

STEP 7: Remove glass pressing block, then separate bezel and toughened glass

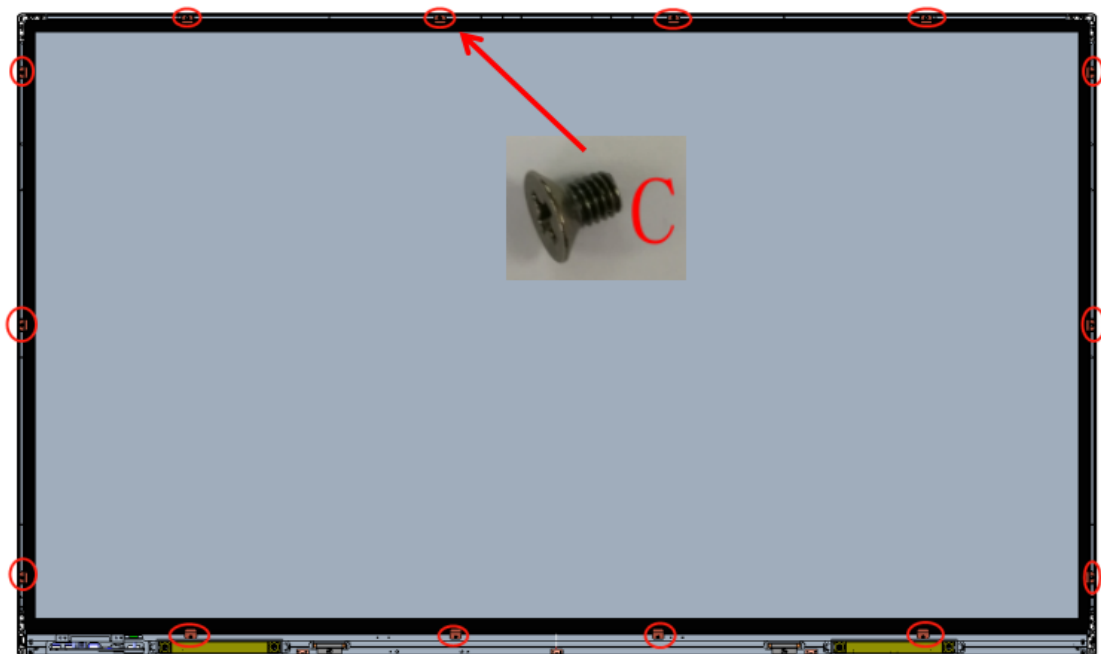

STEP 8: Remove corners

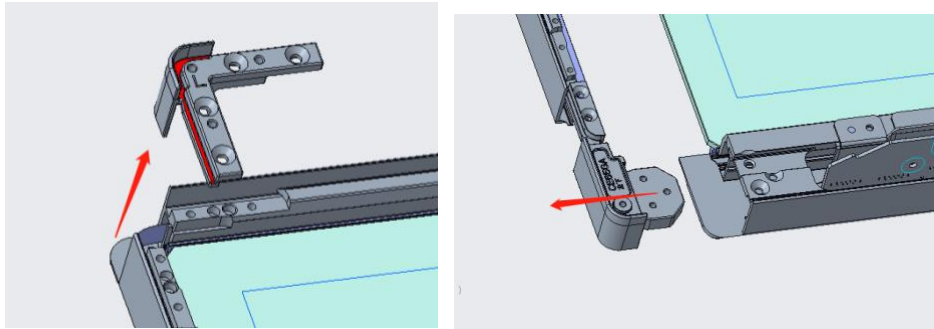

STEP 10: Disconnect the FFC connection line at the upper left, lower left and lower right splices of the touch frame: first disconnect the upper left FFC connection cable and pull out the upper touch frame; then disconnect the lower left FFC connection cable and pull out the left touch frame; then disconnect the lower right FFC connection cable and pull out the right touch frame; finally pull out the lower touch frame.  
 (Note: Use tweezers to push out the touch frame from one side of the bezel to the other side, and pull out the touch frame by hand on the other side. Disassembly order: top - left (right) - bottom)

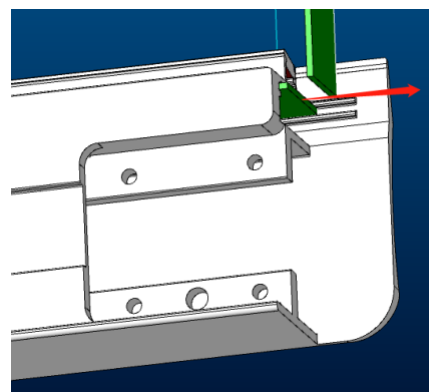
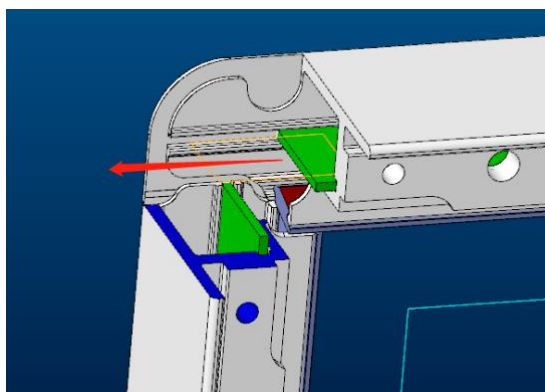
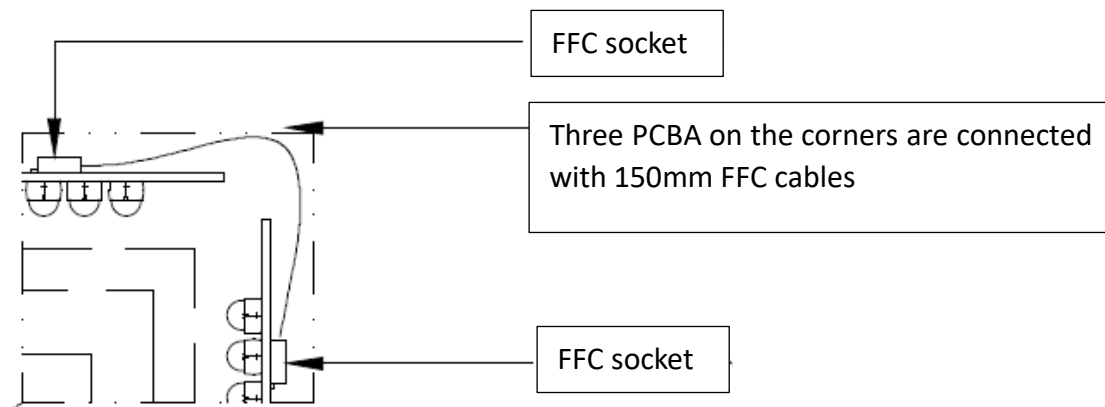

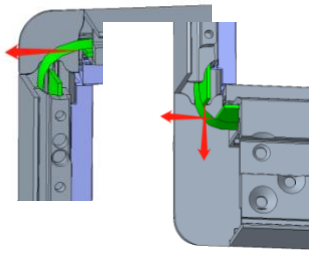

STEP13

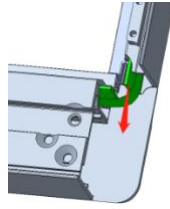

Completed.

---

## Internal Cables

### I. Cable Connection Guide

Part Name	Part No	Cable Connection Guide
1.TCON FFC	004.050.0059757	Main board CNW1 to TCON board CN1
2.WiFi FFC	004.050.0059758	WiFi connector board CN2 to main board CN3
3.COF FFC	004.050.0004183	TCON board to panel
4.Touch cable	004.050.0056504	Main board CN4 to touch frame CN1
5.Speaker cable	004.050.0055848	Main board CNA2 to speakers

### II. Cable Connection Diagram

#### 1. TCON FFC

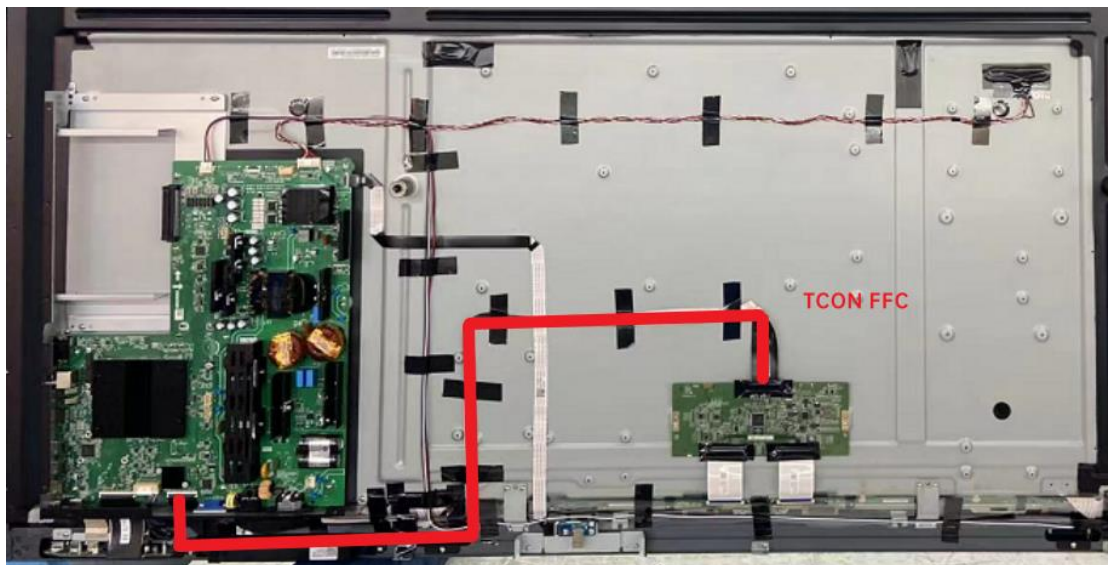

#### 2. WiFi FFC

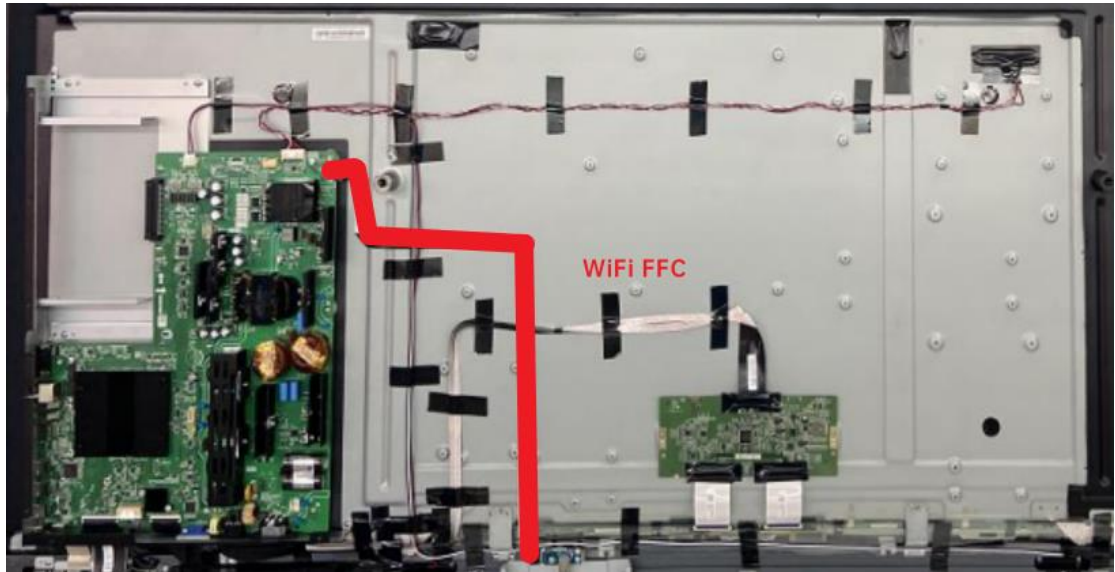

3.COF FFC

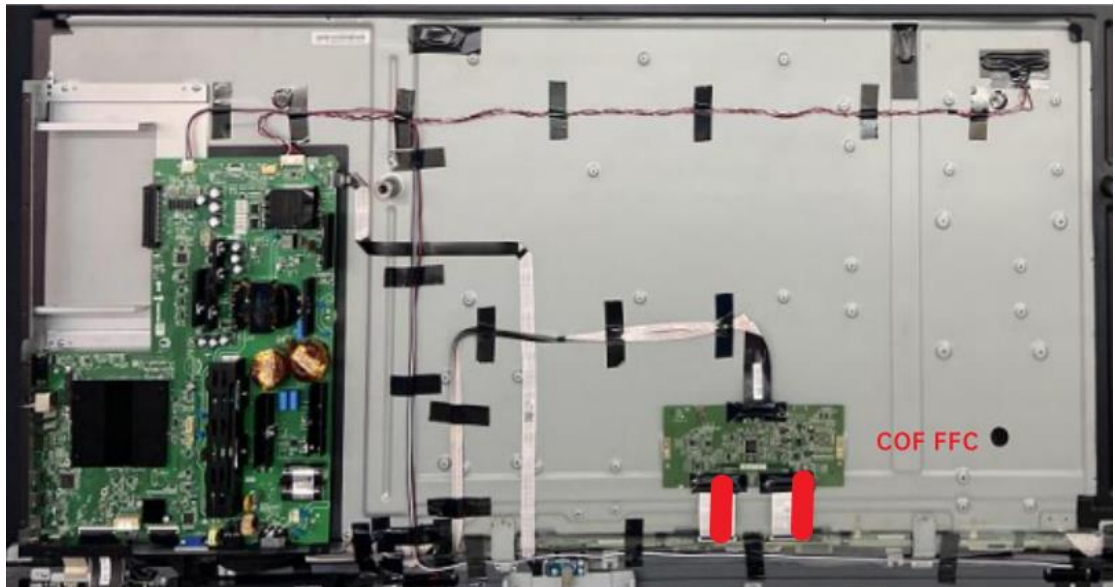

---

## Key Parts List (For reference only)

Part No	Component Name	Description	Quantity
004.034.0053122	75" TCON	TCON-3429A1002J2511	1
004.064.0052911	Touch Frame	W05T20,E30A75N-C-A1	1
004.057.0056201	Main Board	TP.T982.420W D2,4GB RAM,32GB ROM	1
004.057.0054631	USB board	SRKM.HDMI_USB-C.03C	1
004.057.0000672	WIFI connector board	SRC.WiFi_AP_TRAN.02C	1
004.028.0052722	Speaker	190x20.6x39mm,180~ 20000Hz,6ohm,16W,78dB	2

---

# Principle of Key Components

## I. Main board

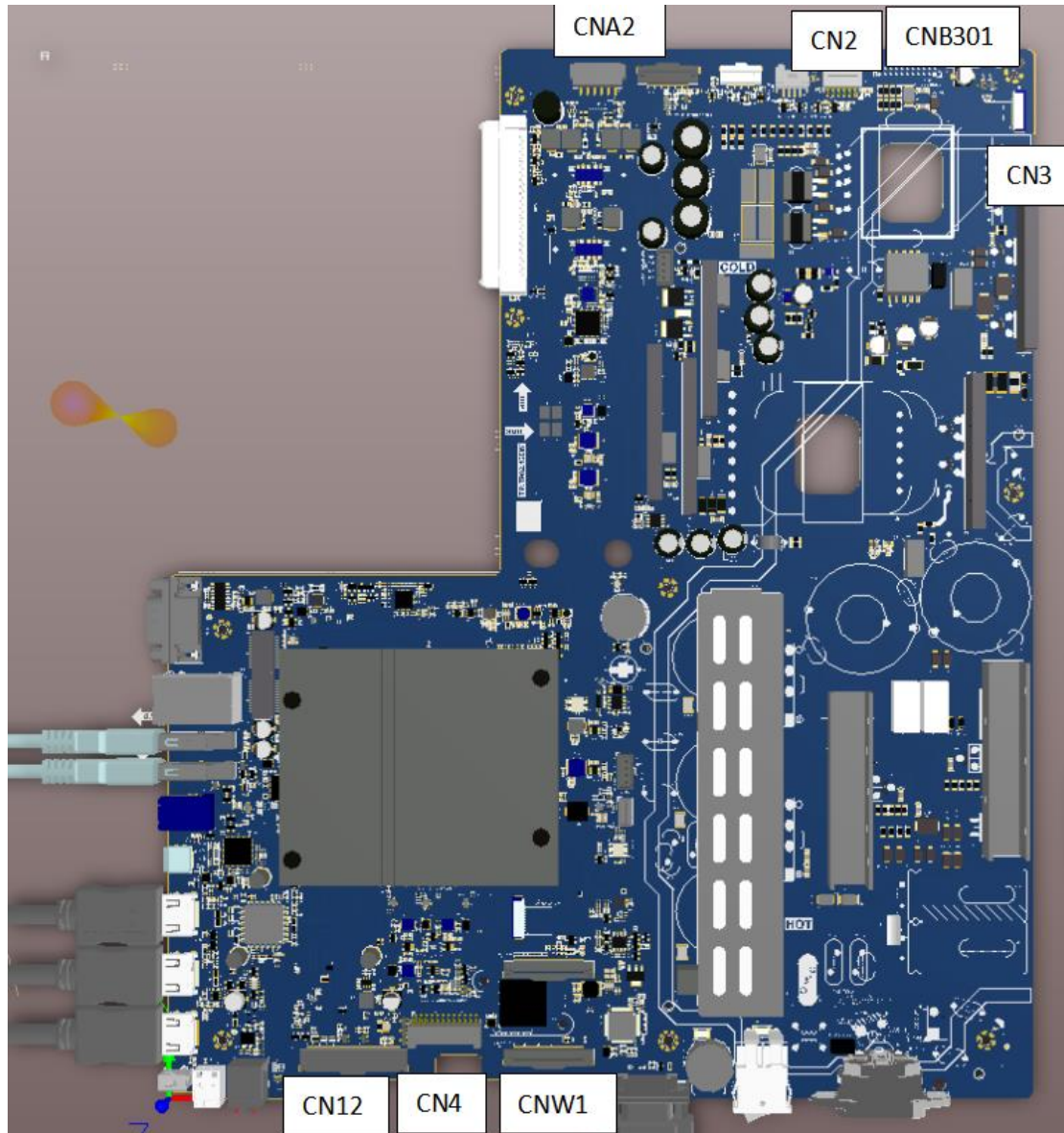



CN12 front 68PIN FPC socket

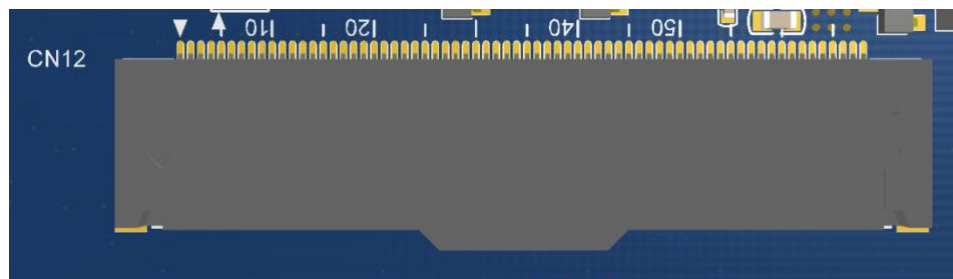
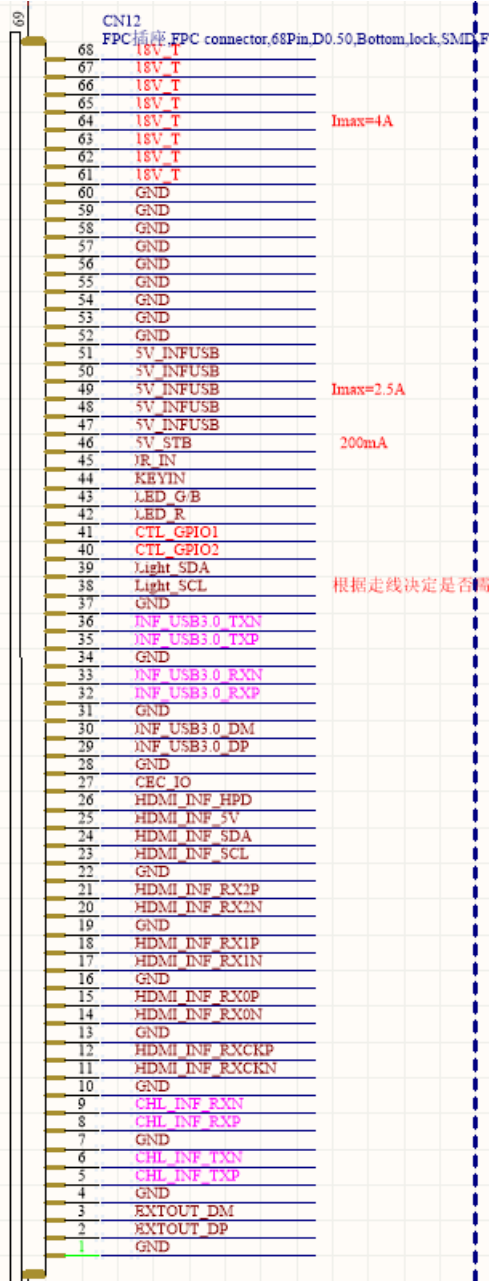

# CN101 OPS Connector

## II2.0)

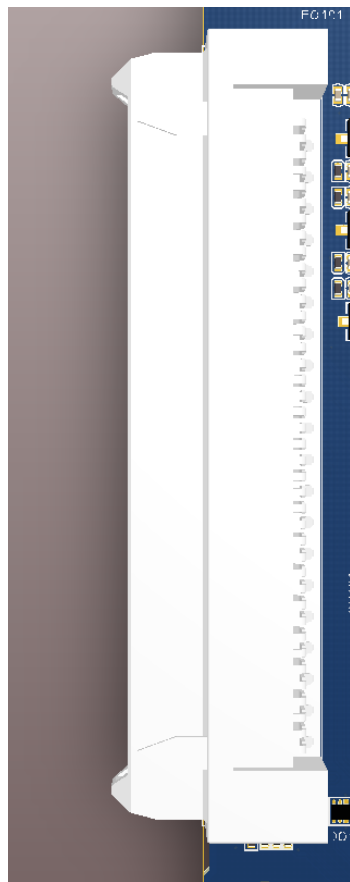
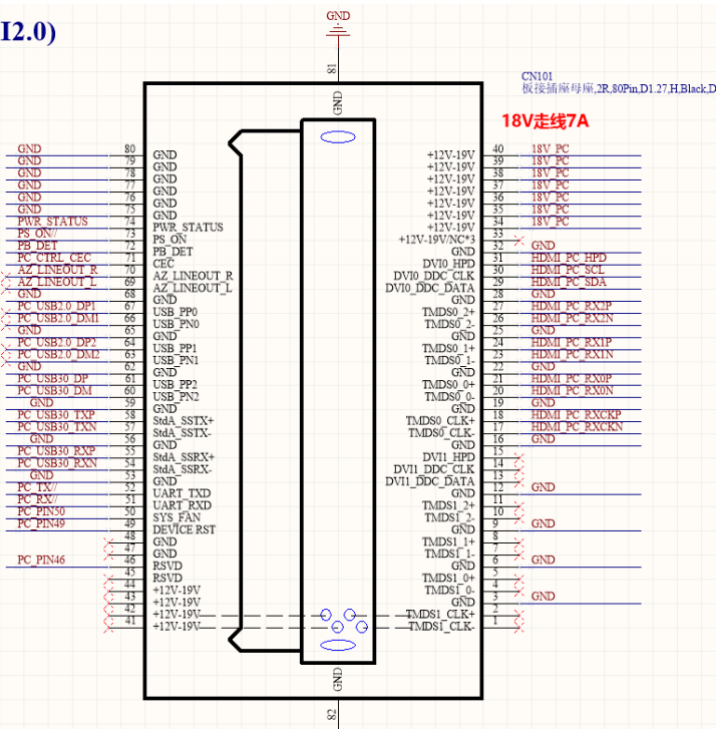

### CNW1 VBO Connector

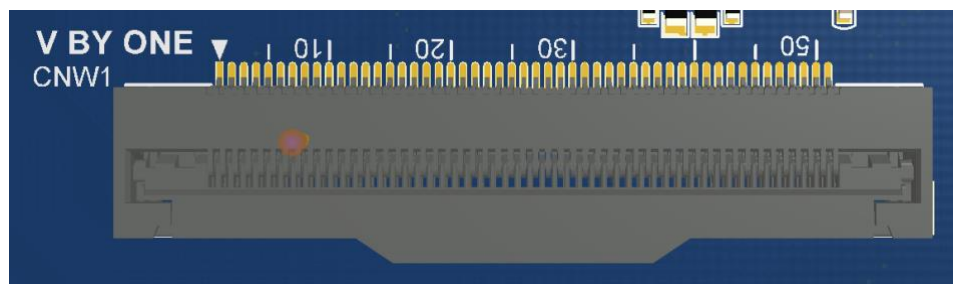
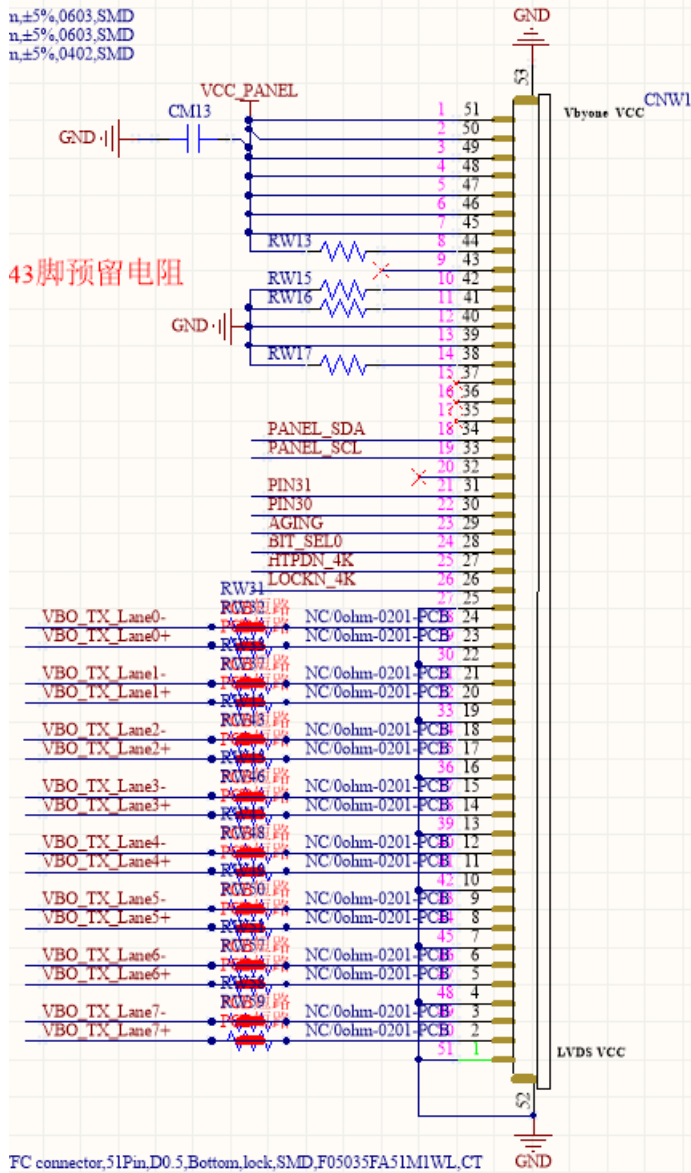

CN2 Connector

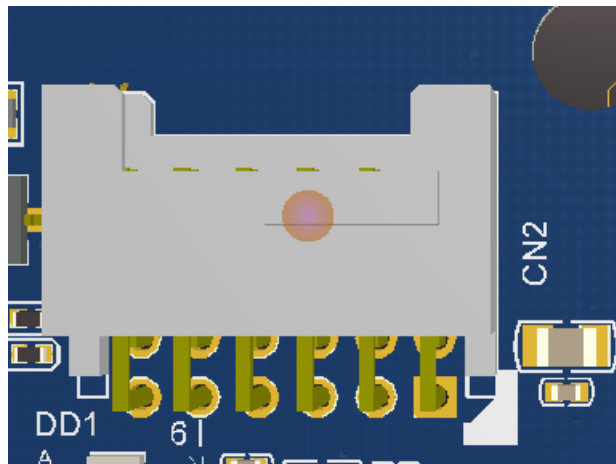
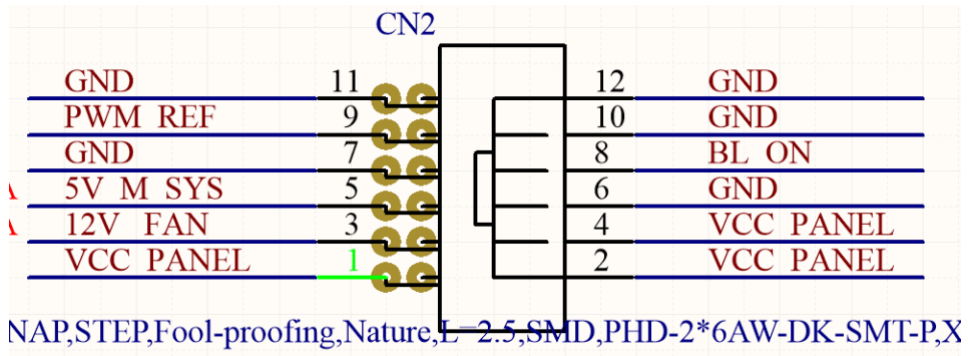

CNA2/CNA16 Speaker Connector

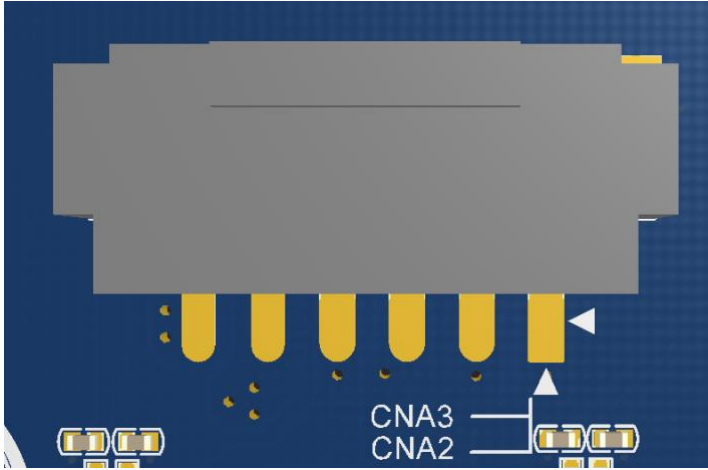
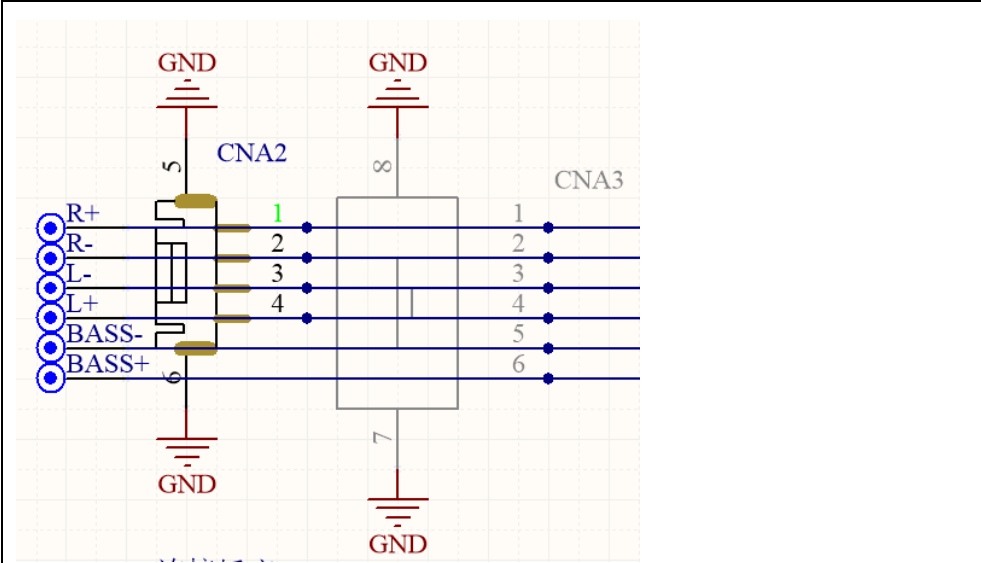

CN4 Main board multiple function connector

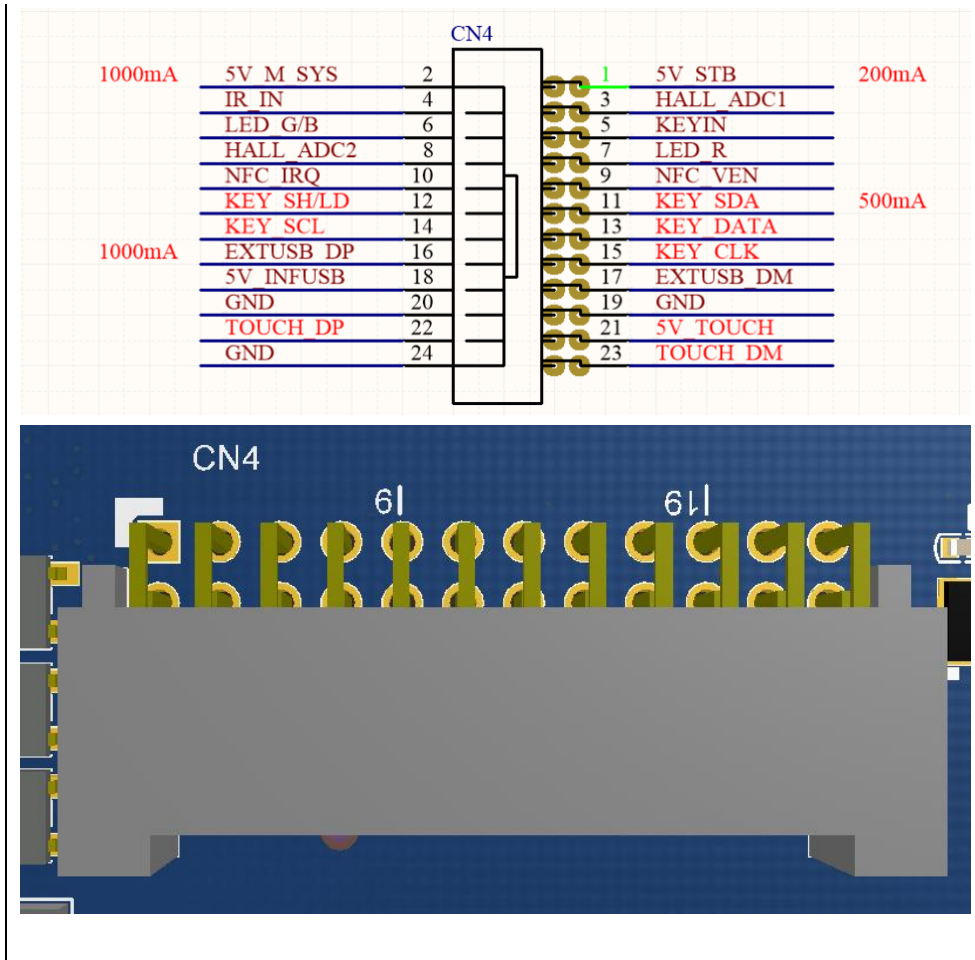

CNB301 Backlight Connector

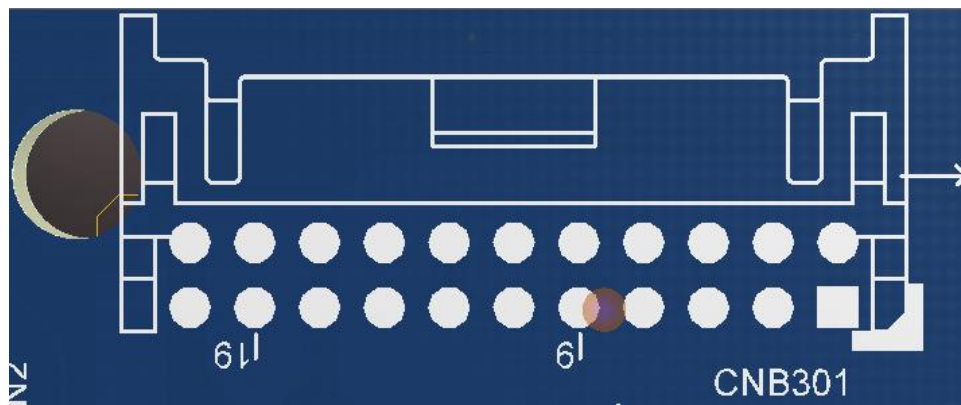
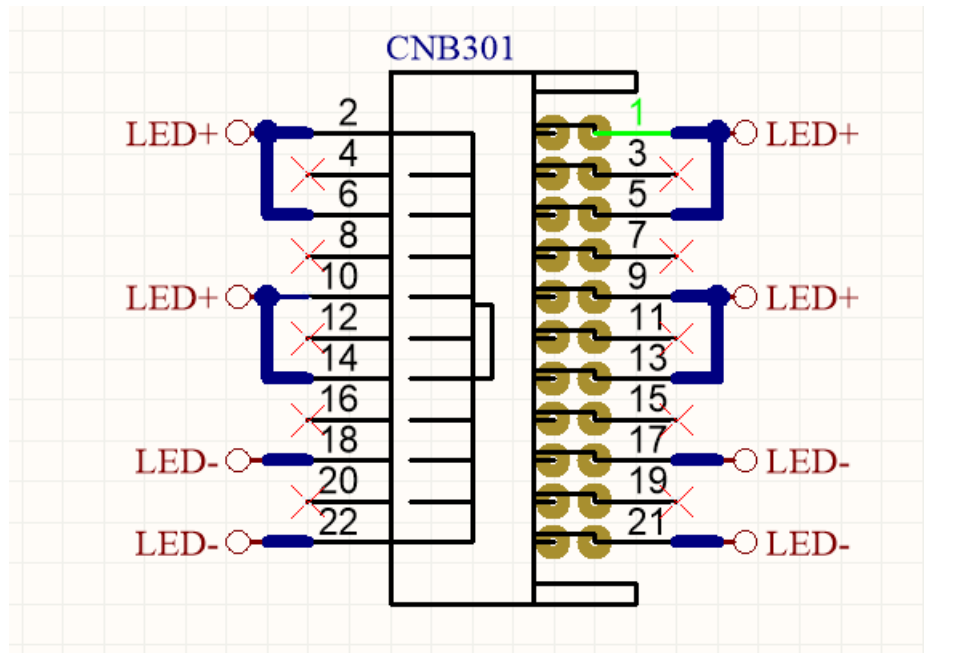

CN5 WIFI Connector

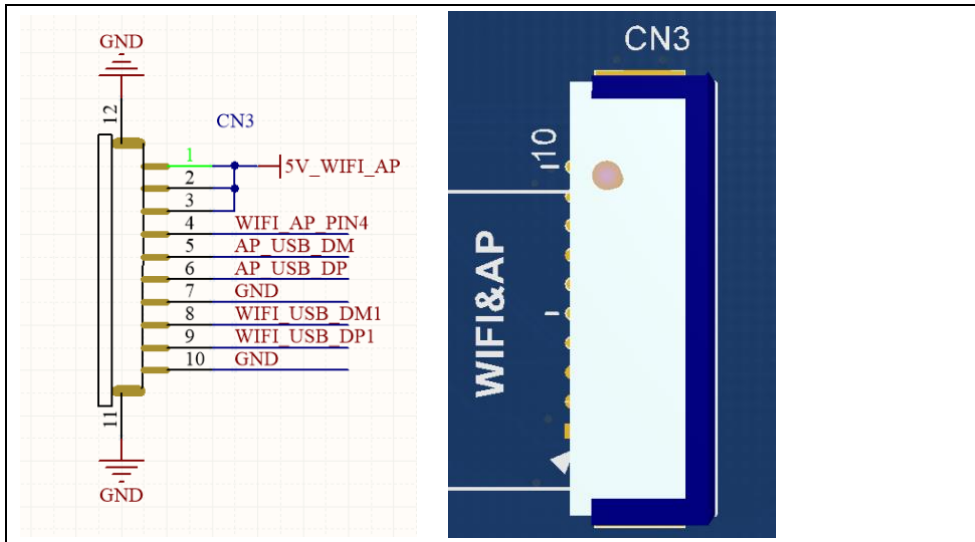

## II. SI07 WiFi Connector board

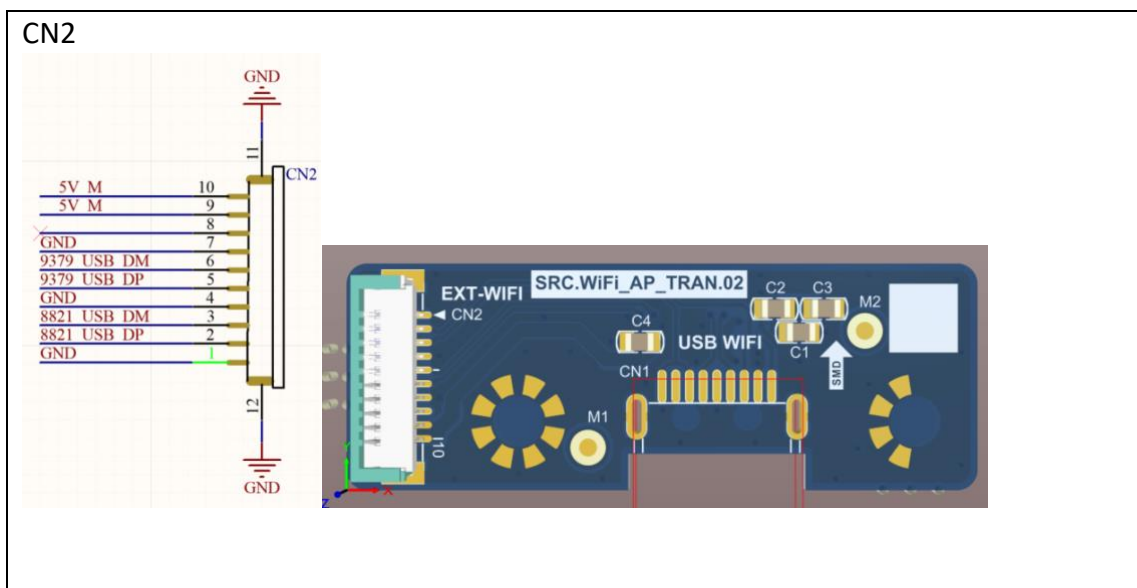

## III. Touch Frame

### 1. Top view of touch frame main board



### 2. Back view of touch frame main board



### 3. Touch Cable Connector of Touch frame main board



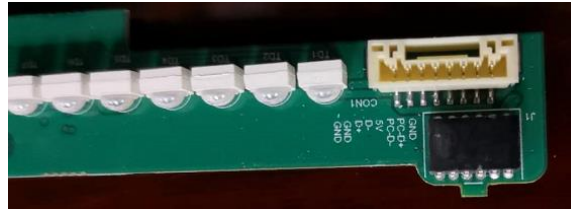

#### 4. Touch Frame Connector Pin Definition

Pin	Define	Description
1	PGND	Ground connect to board
2	GND	Ground
3	USB DP	USB FS data cable D+
4	USB DM	USB FS data cable D -
5	VCC	+5V
6	RXD	Serial port data receiving
7	TXD	Serial port data transmission
8	GND	Ground

A schematic diagram of an 8-pin connector. The pins are numbered 1 through 8 from left to right. A dimension line above the pins indicates a pitch of 1.25mm between adjacent pins. The diagram shows the physical layout of the pins and their electrical connections to a board.

---

## Troubleshoot steps

### I. LED does not turn red.

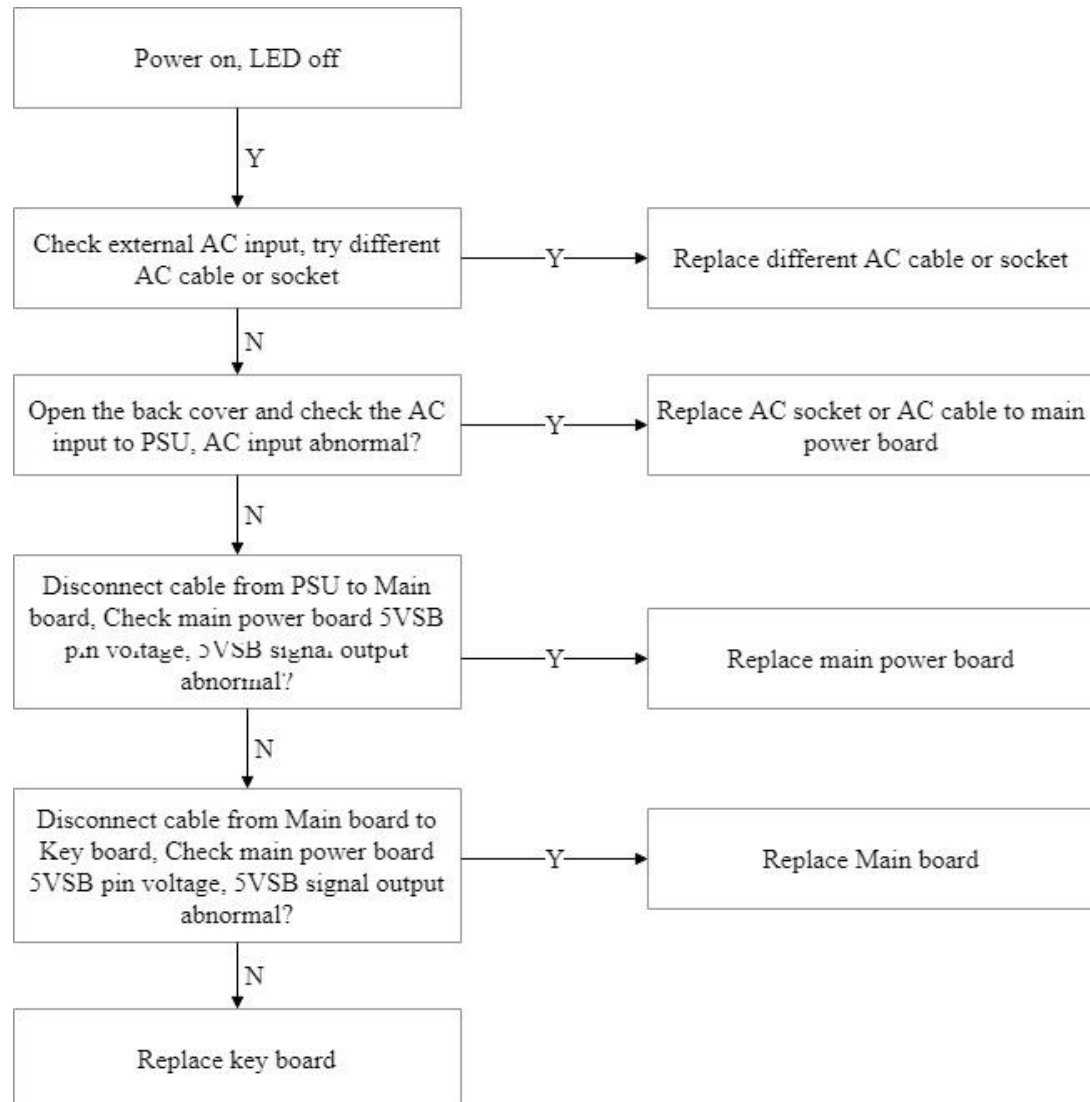

## II. LED does not turn blue.

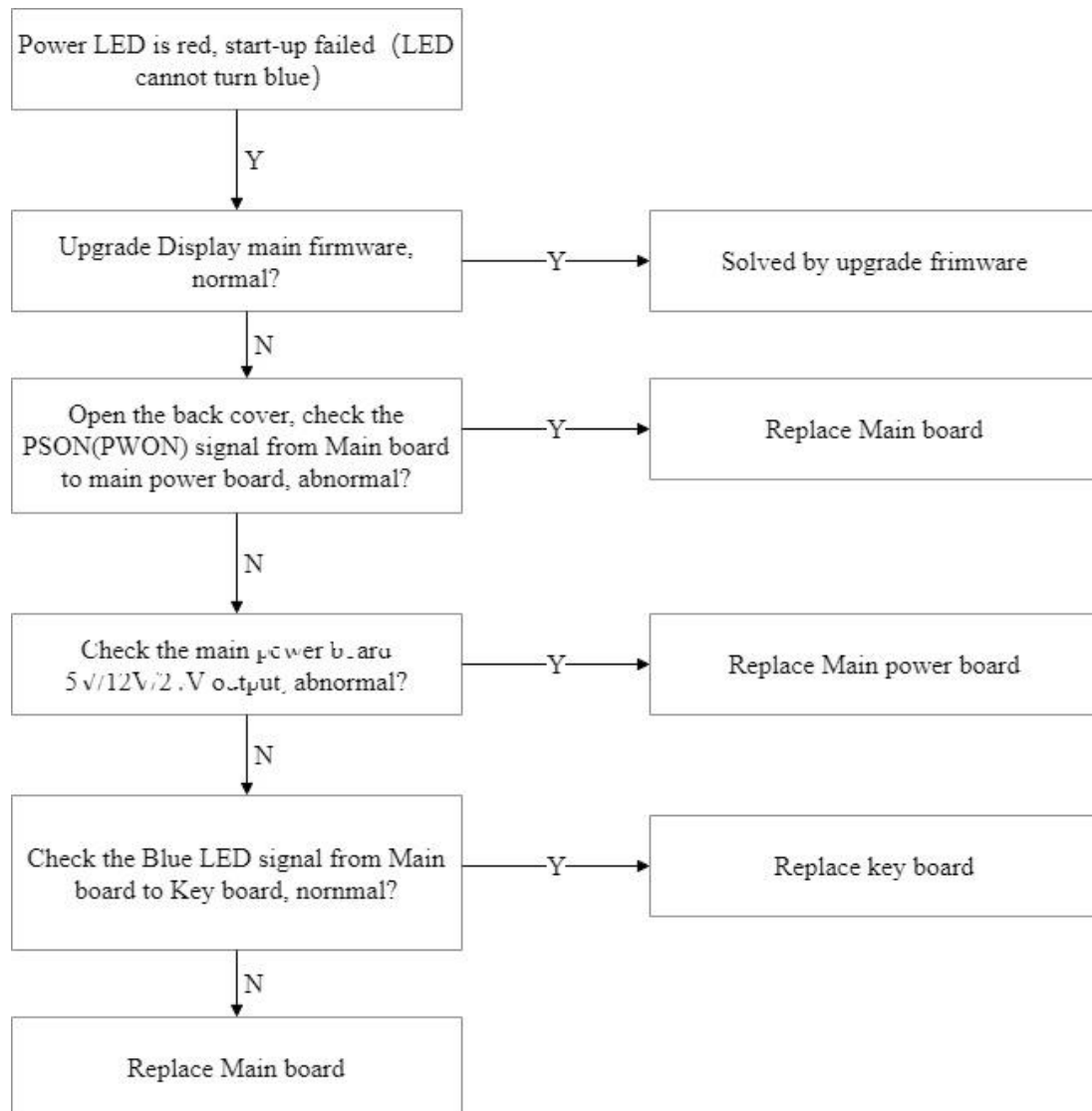

### III. Touch issue

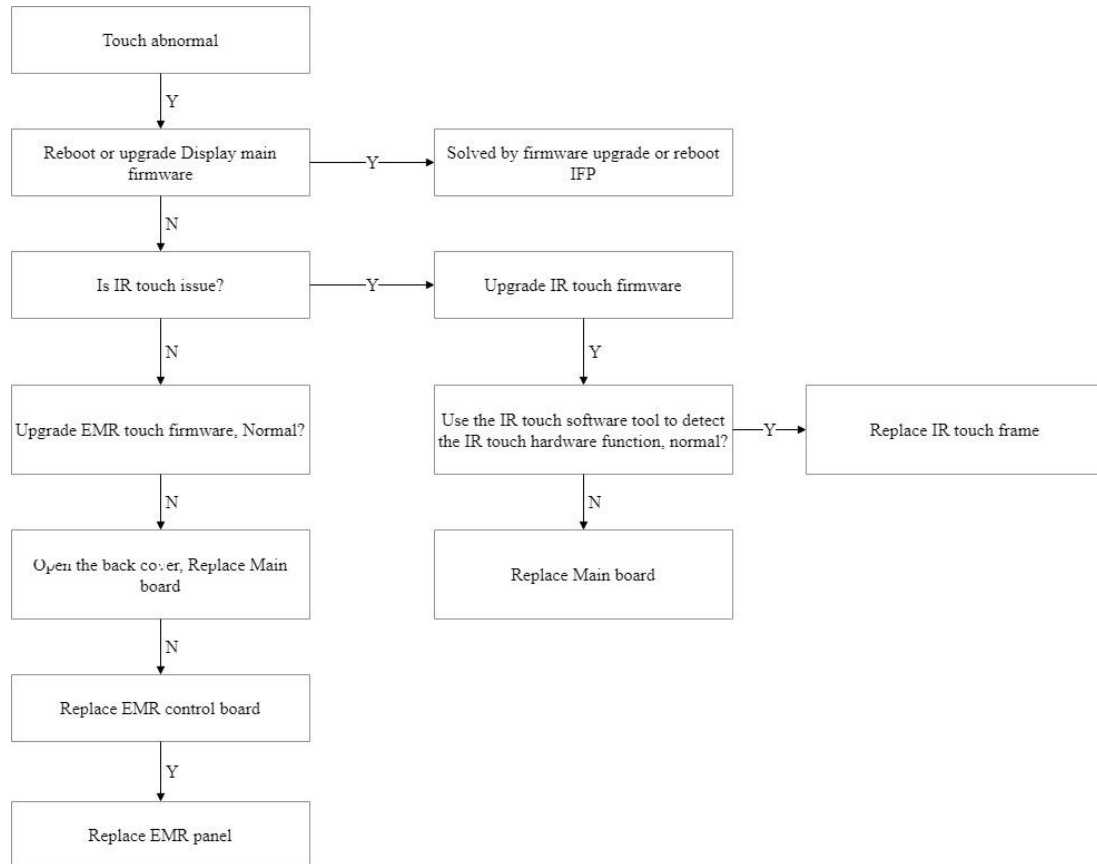

## IV. PC issue

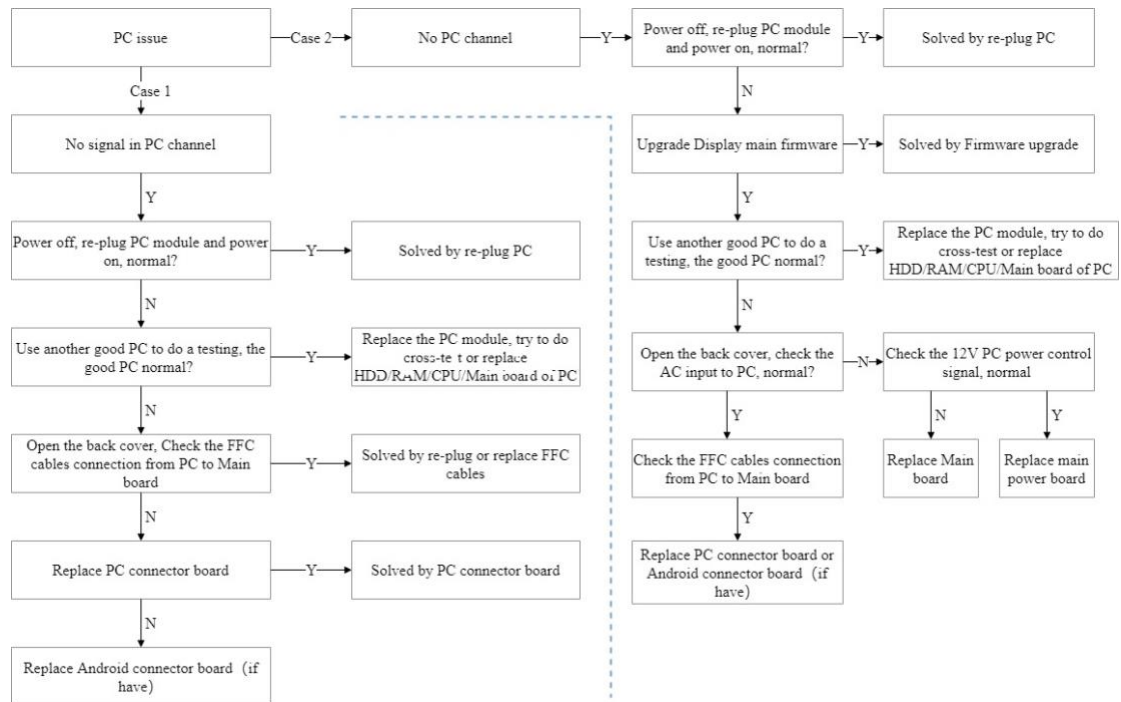

## V. LED turn blue but no backlight

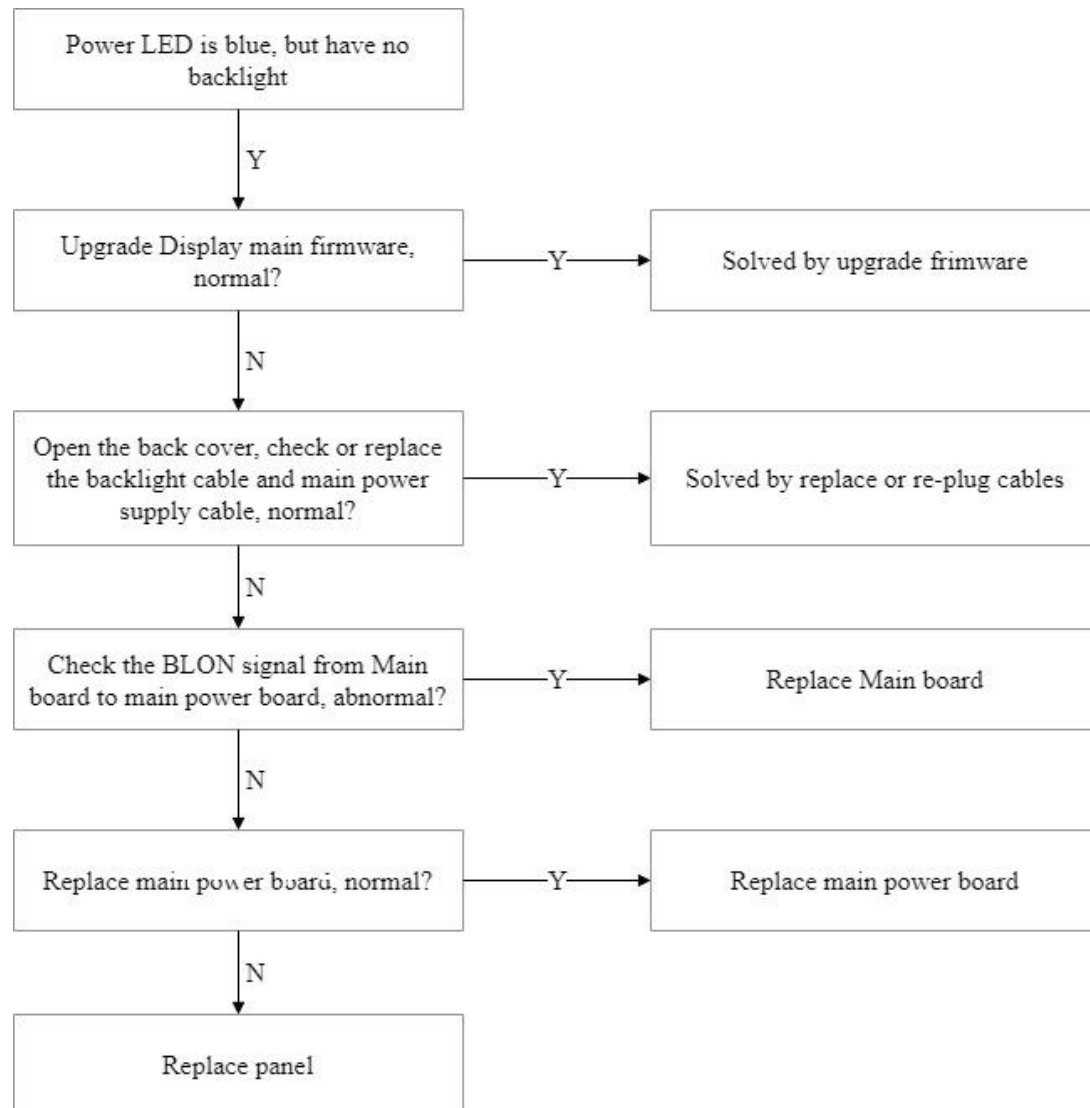

---

# Firmware update procedure

## I. Upgrade All

### 1. Debug Menu Upgrade Procedure (recommend)

#### Tools:

- (1) USB disk (Format FAT32) \*1PCS.
- (2) Remote controller \*1PCS.

#### Procedure:

- (1) Format the USB disk as FAT32.
- (2) Extract upgrade file to the U disk (FAT32) in the root directory. You will get "upgrade\_982" folder.(contains allupgrade\_v982.bin、MCU.bin)
- (3) Insert USB disk into the USB port of the **main** board.
- (4) Turn on the panel. Press "INPUT 1379" with remote controller, and then the debug menu will pop up. Select Upgrade-> Upgrade All, press "Enter", and confirm.

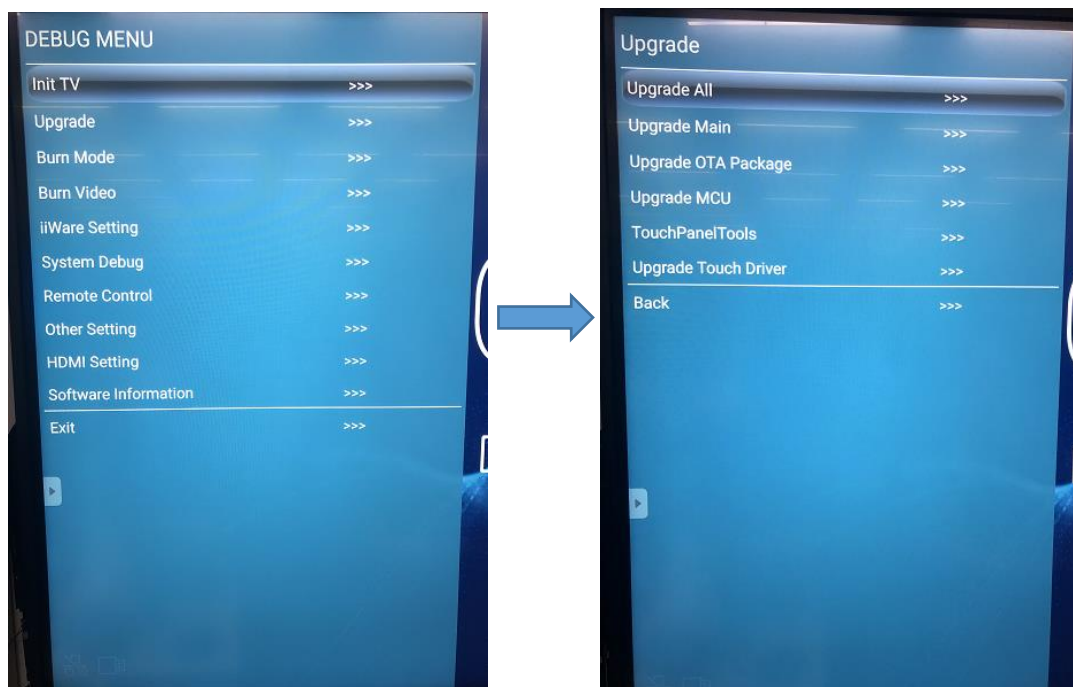

---

(4) The power LED will keep twinkle in red and green during upgrade process. After finished, the panel will reboot and enter Android channel. It will take 4 minutes to complete the upgrade procedure.

**Note:** If MCU upgrade is failure with tips “Do not power off, please re-upgrade MCU”, press “Back” on the remote controller to exit the process. Upgrade MCU separately by Debug Menu – Upgrade – Upgrade MCU.

## **2. Power Key Upgrade Procedure**

### **Tools:**

USB disk (SanDisk, Format FAT32) \*1PCS.

### **Procedure:**

(1) Format the U disk as FAT32.

(2) Extract upgrade file to the U disk (FAT32) in the root directory. You will get "upgrade\_982" folder. Insert USB disk into the USB2.0 port of the main board.

(3) Power on the panel. Press the **POWER** key and hold it until the power LED twinkles in red and blue.

The **display** will upgrade first. When finished, the screen will reboot and upgrade MCU automatically. It will take 4 minutes to complete the upgrade procedure.

## **II. Touch frame Update**

### **Tools:**

(1) USB disk (Format FAT32) \*1PCS.

(2) Remote controller \*1PCS.

### **Procedure:**

(1) Format the USB disk as FAT32.

(2) Extract upgrade file to the U disk (FAT32) in the root directory. You will get a “.bin” touch file. Insert USB disk into the USB port of the **main** board.



(3) Turn on the panel. Press "INPUT 1379" with remote controller, and then the debug menu will pop up. Select

Upgrade-> TouchPanelTools, press "Enter", long press the "App version"

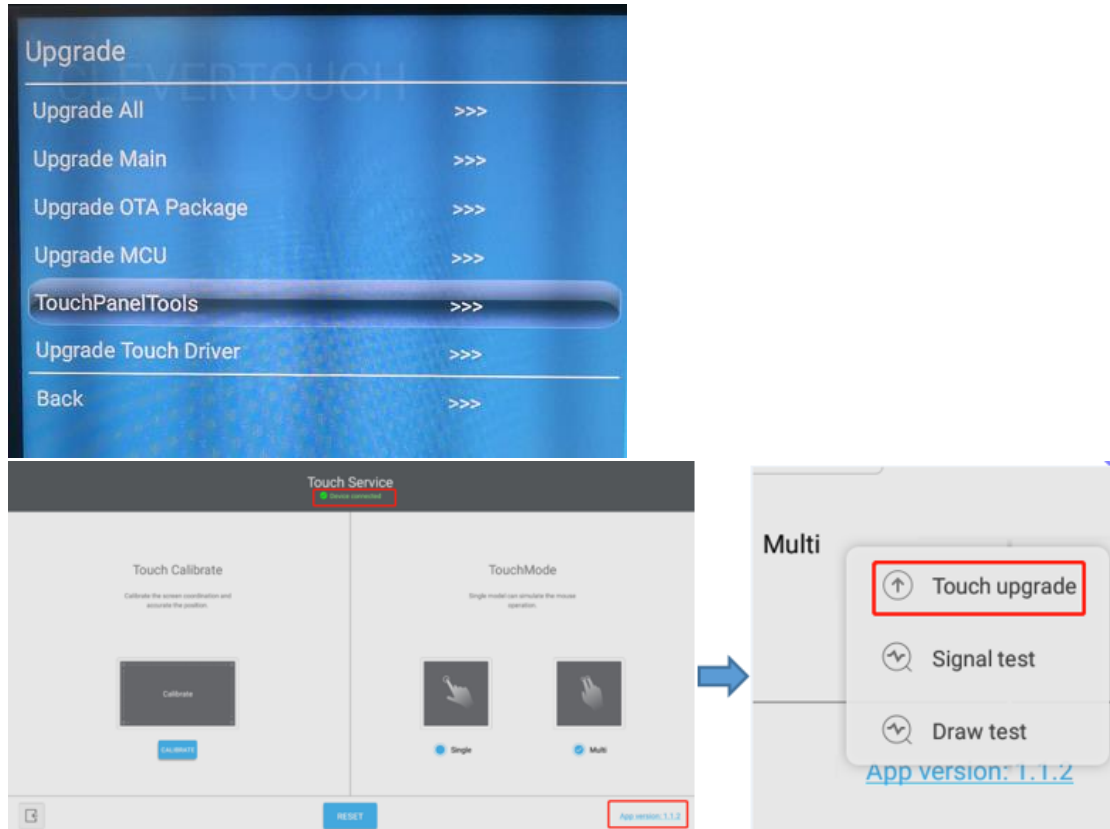

(4) Select "Touch upgrade" and get into the upgrade interface, choose the touch file(bin file) from the USB disk, press "START UPGRADE"

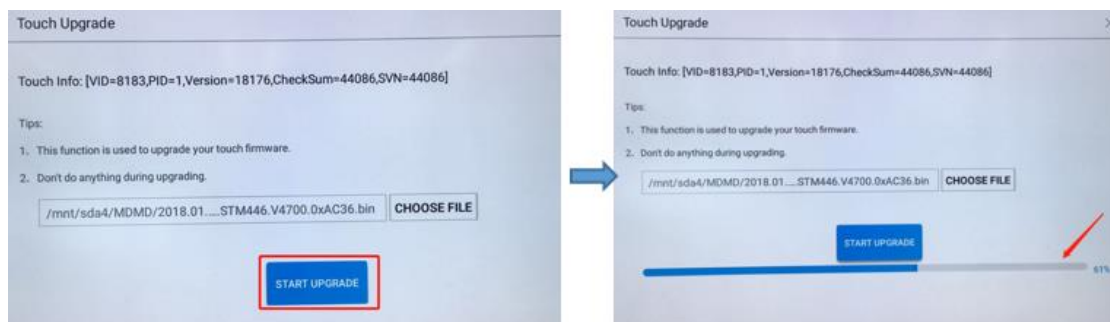

(5) After upgrade finished, press the "X" button in the right corner and exit.

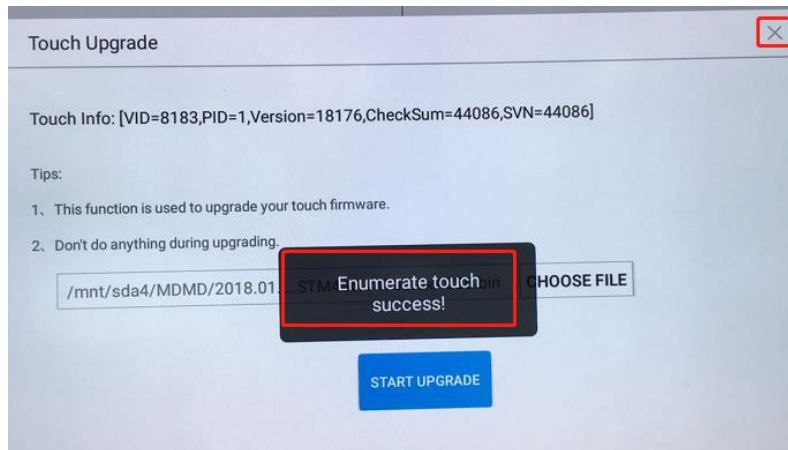

**Note:**

When running the “TouchPanelTools” application, the Touch Service should be showing “Device connected”. If not, please reboot and upgrade again.

